



THE NEW YORK BLOWER COMPANY
7660 Quincy Street
Willowbrook, IL 60527-5530

Visit us on the Web: <http://www.nyb.com>
Phone: (800) 208-7918 Email: nyb@nyb.com

INSTALLATION
MAINTENANCE,
OPERATING
INSTRUCTIONS

IM-195

PLENUM FAN CUBE AND BACKDRAFT DAMPER ASSEMBLY INSTRUCTIONS

ASSEMBLED FAN CUBE

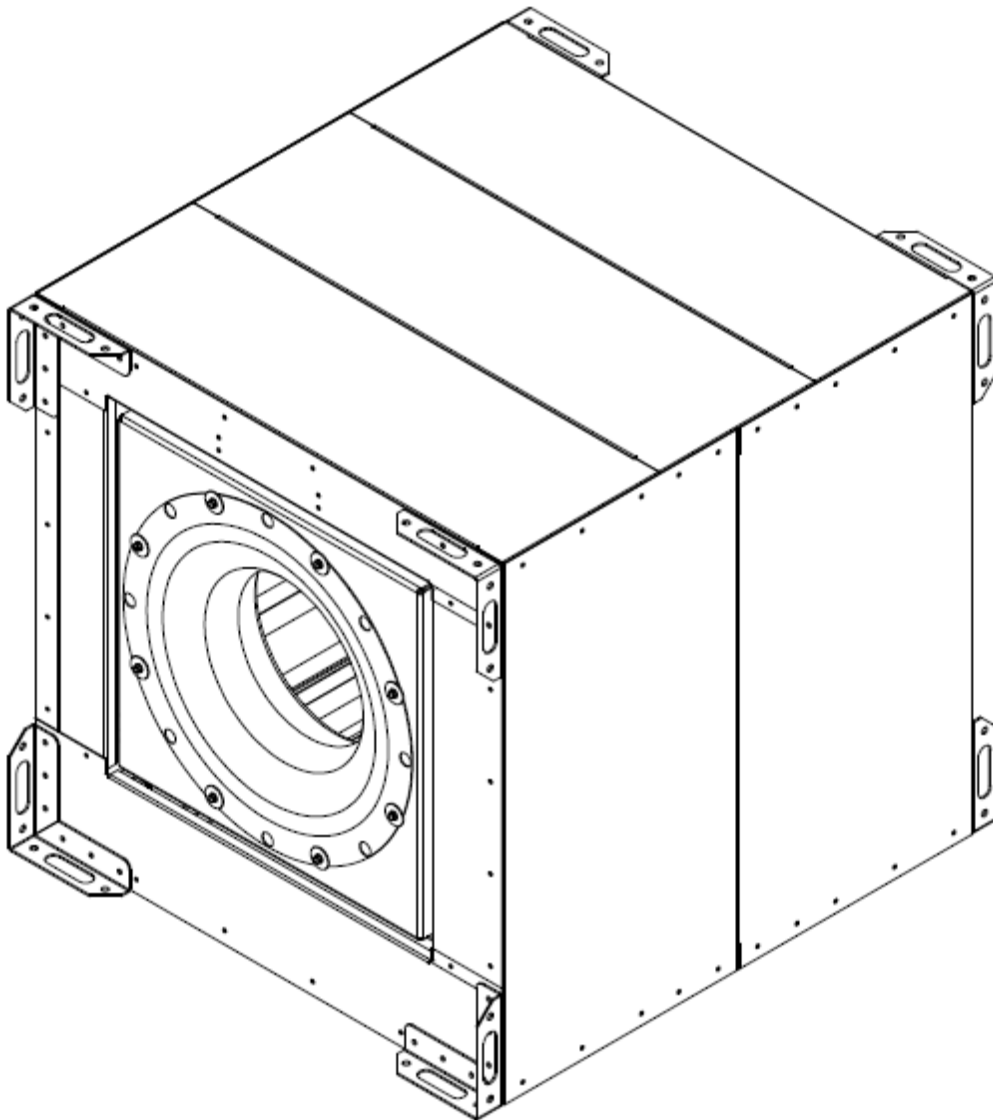

PARTS AND HARDWARE

Parts List:

- (1) Base Subassembly
- (1) Top Panel Subassembly
- (1) Inlet Wall Subassembly
- (2) Side Wall Subassemblies
- (1) Plenum Fan Assembly
- (1) Hardware Kit

Hardware Kit:

- Self-Drilling Tap Screws
- Fan Wall Gasket Seal
- Thrust Restraint Bracket
- Bolts, nuts for Restraint Bracket
- (8) Corner Brackets

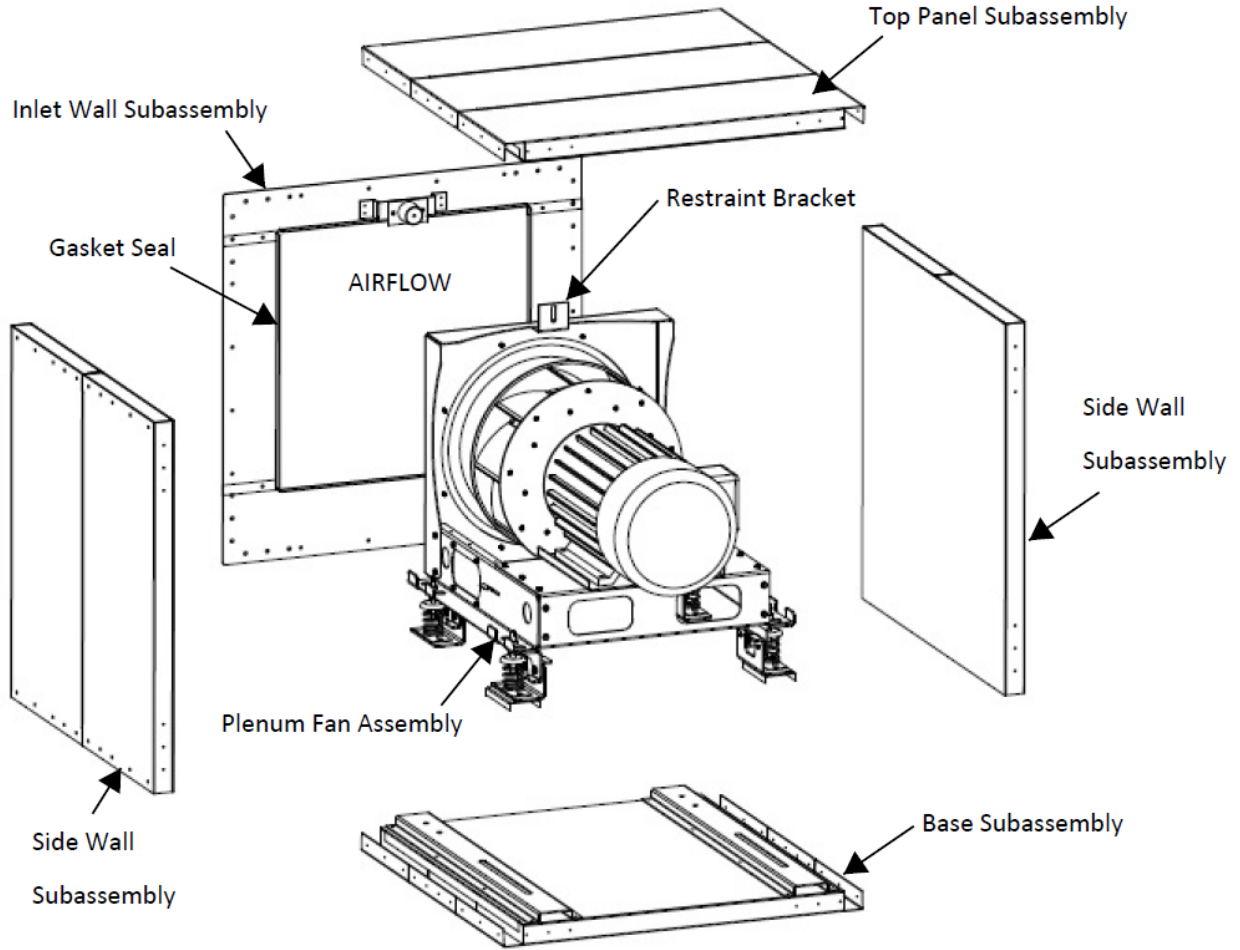

ASSEMBLY INSTRUCTION

1. Set Base Subassembly on a level surface. Base subassembly may be set on a pair of boards to allow for lifting with a fork truck later.
2. Remove bolts from base channels and set Plenum fan on Base Subassembly with bottom holes in isolators lined up with holes in base channels. Refasten bolts and tighten down to secure fan.
3. Remove isolator restraint bolts and restraining clips from spring isolators under fan. Fan should be freely floating on springs at this point.
4. **Orient Side Wall Panel so that the side with the most holes is on the air entering side of the fan cube.** Lower Side Panel Subassembly into left or right hand slot in Base Subassembly. Fasten in place with provided screws.
5. Repeat for opposite side wall. Larger sizes **DO NOT ALLOW THE SIDE WALLS TO FALL OVER AND BEND.** Larger sizes will require more than one assembler.
6. Bolt Restraint Bracket to top holes in Plenum Fan. **Restraint Bracket tucks under top fan flange and does not sit on top of fan flange.**
7. Set Top Panel Subassembly on top of two Side Walls allowing two Side Walls to slip inside Top Panel slots. Air Entering side of Top Panel has more holes than air leaving side.
8. Mount Gasket Seal to air inlet opening of Inlet Wall. Push Gasket on to inlet perimeter flange until gasket is snug.
9. Orient Inlet Wall with Gasket Seal toward fan and Rubber Isolator toward the top and fasten in place with provided screws.
10. Using a ruler or paint stir, gently push outside lip of Gasket Seal around inlet perimeter of plenum fan.
11. Using bolt provided, fasten Restraint Bracket to Rubber Isolator. Be sure that Gasket Seal is seated properly.
12. **For shipping purposes all 4 Z clips (2 in each) must be installed in back isolation lock down brackets.**

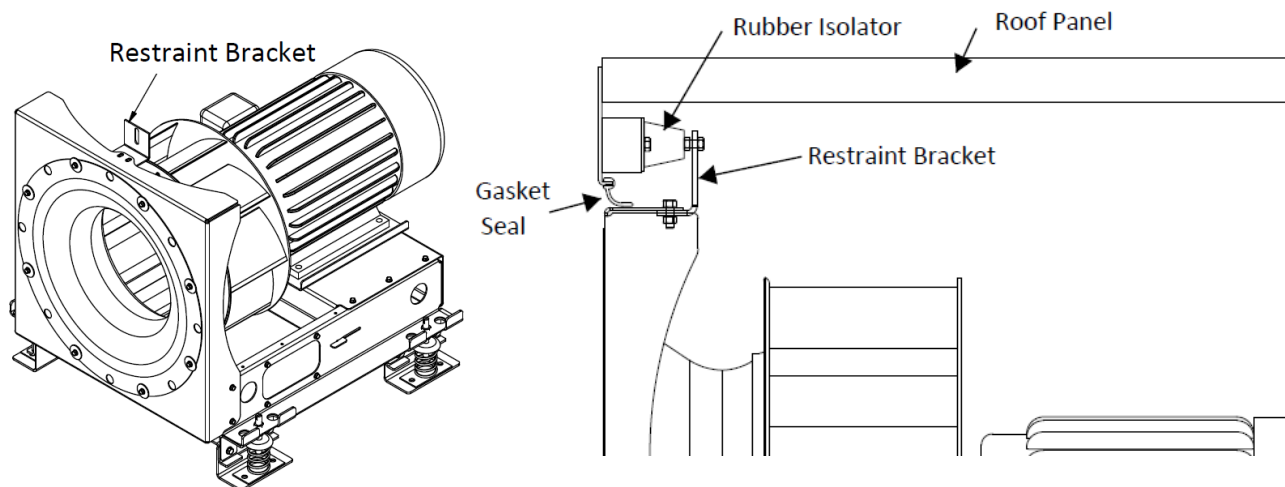

OPTIONAL INLET DAMPER

1. Locate (4) identical Damper Sleeve panels. Form a square with the (4) panels with the flange along the width of the panel inside the square. Fasten (4) panels together with sheet metal screws provided.
2. Fasten Backdraft Damper to Damper Sleeve as shown with sheet metal screws provided. Damper blades should swing in to Damper Sleeve.
3. Apply provided self-adhesive gasket to Damper Sleeve opposite the Backdraft Damper.
4. Screw Damper Sleeve to the air inlet side of the Fan Cube with sheet metal screws provided.

